



NW-PH 1632 Nite Window with Pass Hopper

Nite Window with Pass Hopper fits into wall opening of 16.25" x 32.25". Aluminum frame has clear or dark bronze anodized finish. Unit includes PHE-1 stainless steel Pass Hopper,* weatherstripped for exterior use and our No. 6-FR* stainless steel draft-free talk thru. Window has 1.25" thick Level I bullet resistant acrylic glazing.

Specify frame finish:

Clear or dark bronze anodized aluminum

Glazing:

1.25" Level I bullet resistant acrylic

* PHE-1 Pass Hopper and No. 6-FR Talk Thru described in further detail in other sections of this catalog.



NW-DT 1624 Nite Window with Deal Tray

Compact Nite Window with Deal Tray fits into 16.25" x 24.25" wall opening. Glazing is 1.25" thick acrylic with Level I bullet resistant protection and aluminum frame in clear or dark bronze anodized finish. Window unit has No. 6-FR* stainless steel draft-free talk thru and stainless steel deal tray with hinged draft closure.

Specify frame finish:

Clear or dark bronze anodized aluminum

Glazing:

1.25" Level I bullet resistant acrylic

*No. 6-FR Talk Thru described in further detail on page 15 of this catalog.

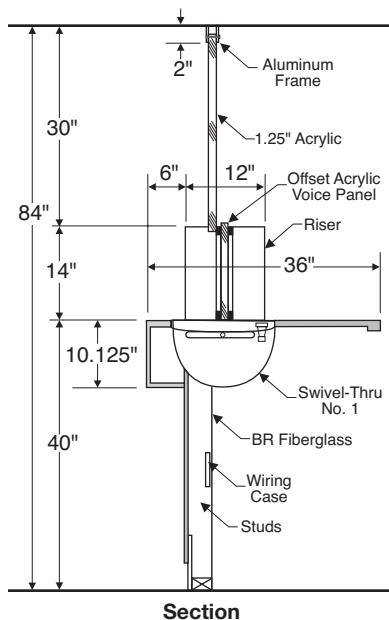

Bullet Resistant Teller Counter Model BRTC-STH

Bullet Resistant Teller Counter Model BRTC-SWTH is furnished with No. 1 Swivel-Thru* combination pass thru and deal tray. It has a natural voice transmission acrylic panel at deal area, with acrylic panels above risers set in aluminum frames. Teller counter unit includes counter top, risers and counter front with bullet resistant fiberglass panels on rear side. Electrical duplex outlets are mounted on rear side of risers (wiring by others).

Standard size:

60" wide x 84" high

Glazing:

1.25" Level I bullet resistant acrylic

* No. 1 Swivel Thru described in further on page 6 of this catalog.

